

HORIZONTAL CRYOGENIC STORAGE TANK

EFHA 17 BAR



CRYOLOR ASIA PACIFIC introduces the latest generation vacuum insulated cryogenic tank, the **EFHA**, for Liquid Nitrogen, Oxygen or Argon service. Available in a range of sizes with a Maximum Allowable Working Pressure of **250 psig** (≈ 17 bar). **EFHA** is designed in accordance with **ASME Section VIII Division 1 + Mandatory appendix-44 (cold stretch) with 'U' stamp**.

Moreover, the support legs/saddles used in the EFHA range are calculated to resist high winds and earthquakes according to **IBC code Zone 0 to Zone 4**.

- **A maximum use of Stainless steel:** Only EFHA uses as much stainless in its construction to guarantee the lowest life cycle costs.
- **Components selected for their operational reliability** - mono-bloc pressure building economizer - regulator, safety system with dual relief valves and bursting discs as standard, aluminum star fin pressure building unit.
- **Reduced overall operational costs** - optimized pipe work layout with fewer connections minimize potential

leaks and facilitate operation & servicing, filling assembly isolation valves, proven painting techniques guarantee years of problem free operation.

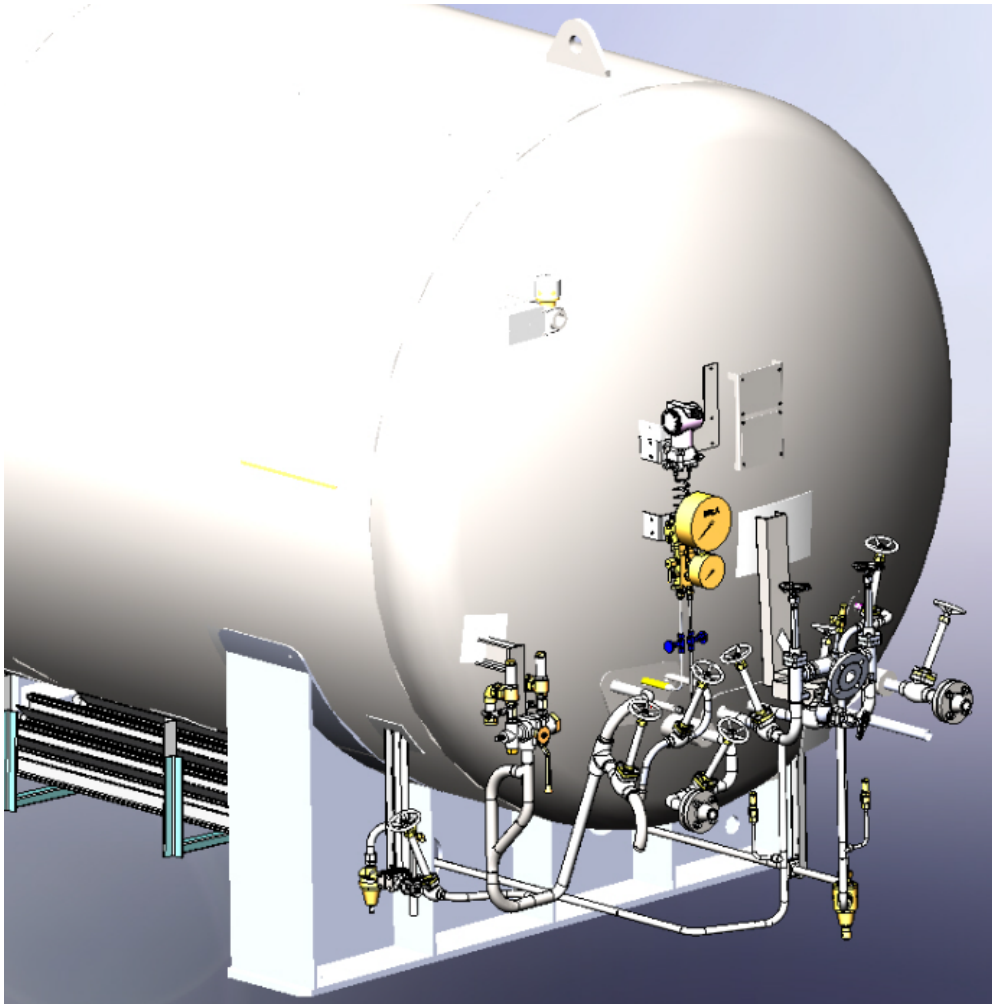

Disclaimer: The image shown above is just a representation of the tank, The actual product may vary on its appearance and size.

HORIZONTAL CRYOGENIC STORAGE TANK

EFHA 17 BAR

TANK VIEW

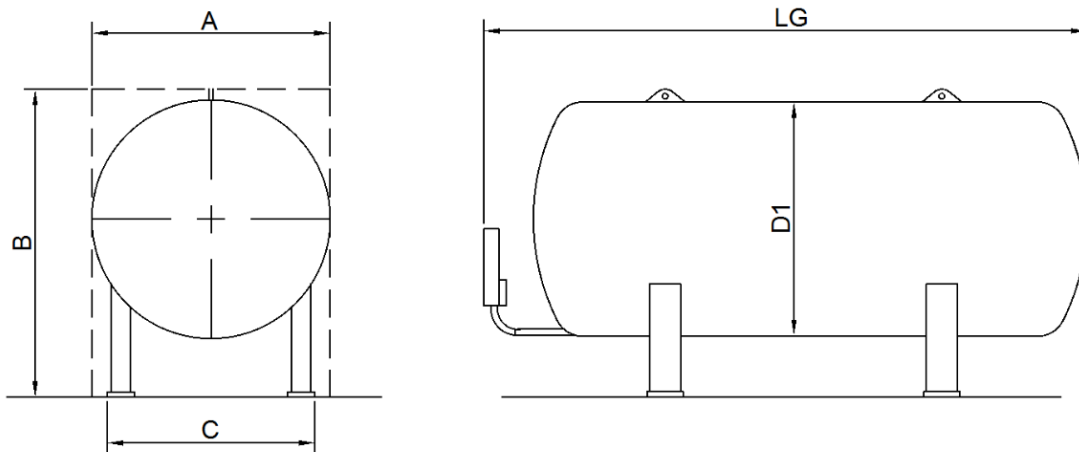
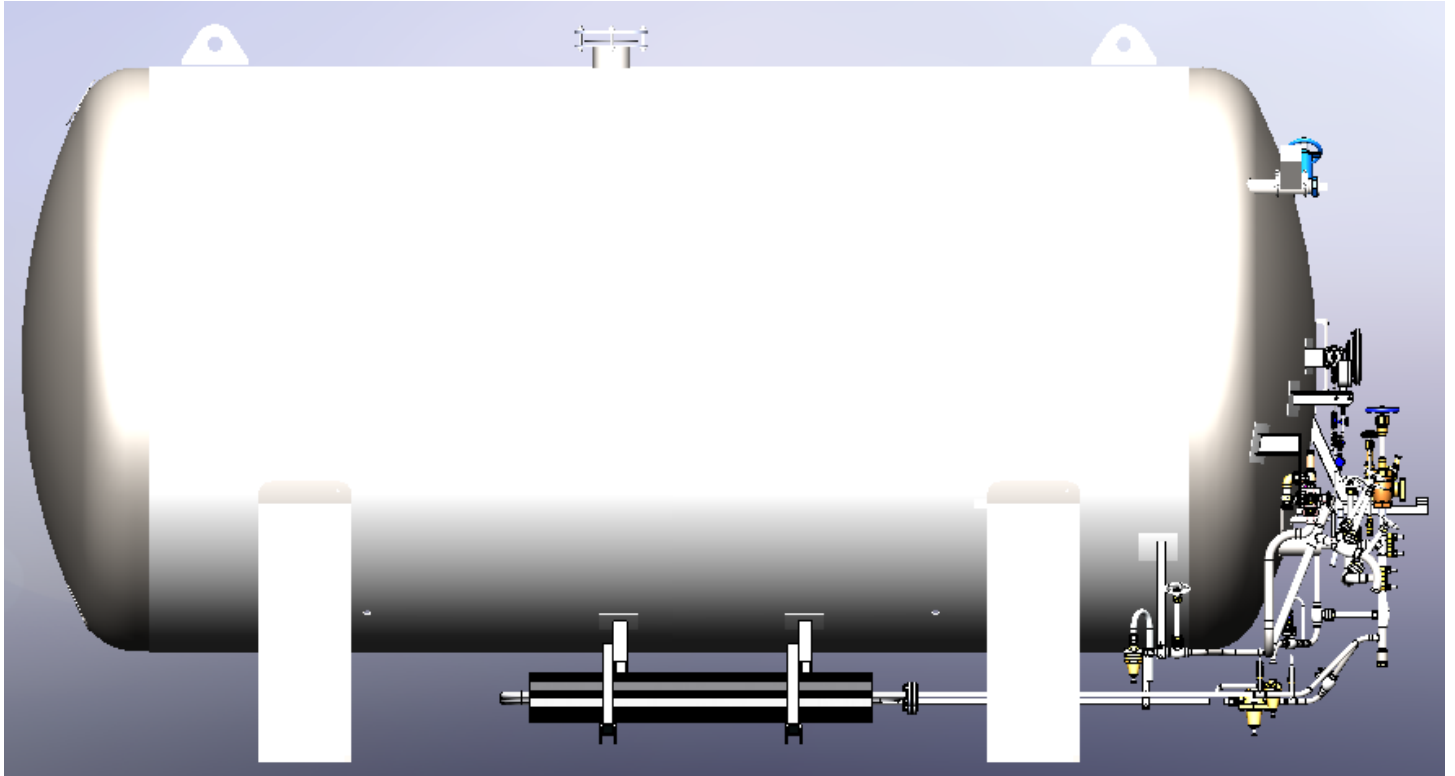

Note: The above picture is not an actual view, the tanks will be built with saddles for larger vessels.

HORIZONTAL CRYOGENIC STORAGE TANK

EFHA 17 BAR



TYPE	EFHAA06 (1.5 KUSG)		EFHA11 (3 KUSG)		EFHA14 (4 KUSG)		EFHA19 (5 KUSG)		EFHA21 (6 KUSG)		EFHA21 (6 KUSG)	
Gross capacity (liters / USG) *	6150	1625	10540	2784	14910	3939	19290	5096	23660	6250	28040	7407
Net capacity (liters / USG) *	5843	1543	10013	2645	14165	3742	18326	4841	22477	5938	26638	7037
Boil off Rate O2 (%)	0.80		0.46		0.40		0.34		0.32		0.30	
Empty weight (kg / lbs)	4800	10582	6200	13669	7600	16755	9100	20062	10500	23149	11900	26235
Weight full Nitrogen (kg / lbs) - LIN	9521	20990	14291	31505	19045	41987	23907	52706	28661	63188	33424	73686
Weight full Oxygen (kg / lbs) - LOX	11466	25279	17625	38856	23762	52386	30009	66159	36146	79689	42294	93242
Weight full Argon (kg / lbs) - LAR	12939	28525	20148	44419	27331	60255	34627	76340	41810	92176	49007	108041
Continuous flow rate For 8 Hours at 8 bar (Nm3/hr)	500											
∅ Diameter (mm / feet)	2200 / 7.2											
LG (mm / feet)	4300	14.1	5500	18.0	7100	23.3	8600	28.2	10235	33.6	11735	38.5
A (mm / feet)	2300 / 7.5											
B (mm / feet)	2850 / 9.3											
C (mm / feet)	2000 / 6.5											

TYPE	EFHA33 (9 KUSG)		EFHA41 (11 KUSG)		EFHA47 (13 KUSG)		EFHA53 (15 KUSG)		EFHA63 (17 KUSG)	
Gross capacity (liters / USG) *	34340	9072	41300	10910	47530	12556	56270	14865	63750	16841
Net capacity (liters / USG) *	32623	8618	39235	10365	45154	11928	53457	14122	60563	15999
Boil off Rate O2 (%)	0.27		0.25		0.24		0.24		0.22	
Empty weight (kg / lbs)	15000	33069	17200	37920	19100	42108	21700	47840	24000	52911
Weight full Nitrogen (kg / lbs) - LIN	41359	91182	48902	107810	55584	122542	64893	143064	72935	160793
Weight full Oxygen (kg / lbs) - LOX	52223	115132	61967	136614	70620	155691	82694	182309	93102	205254
Weight full Argon (kg / lbs) - LAR	60444	133256	71854	158412	81999	180776	96165	212007	108364	238901
Continuous flow rate For 8 Hours at 8 bar (Nm3/hr)	500									
∅ Diameter (mm / feet)	2840 / 9.3									
LG (mm / feet)	8900	29.2	10400	34.1	11700	38.4	13400	44.0	15100	49.5
A (mm / feet)	2840 / 9.3									
B (mm / feet)	3100 / 10.2									
C (mm / feet)	2600 / 8.5									

* Manufacturing tolerance : ± 4%

Note: Trycock level is 95%.

HORIZONTAL CRYOGENIC STORAGE TANK

EFHA 17 BAR

FLOW DIAGRAM

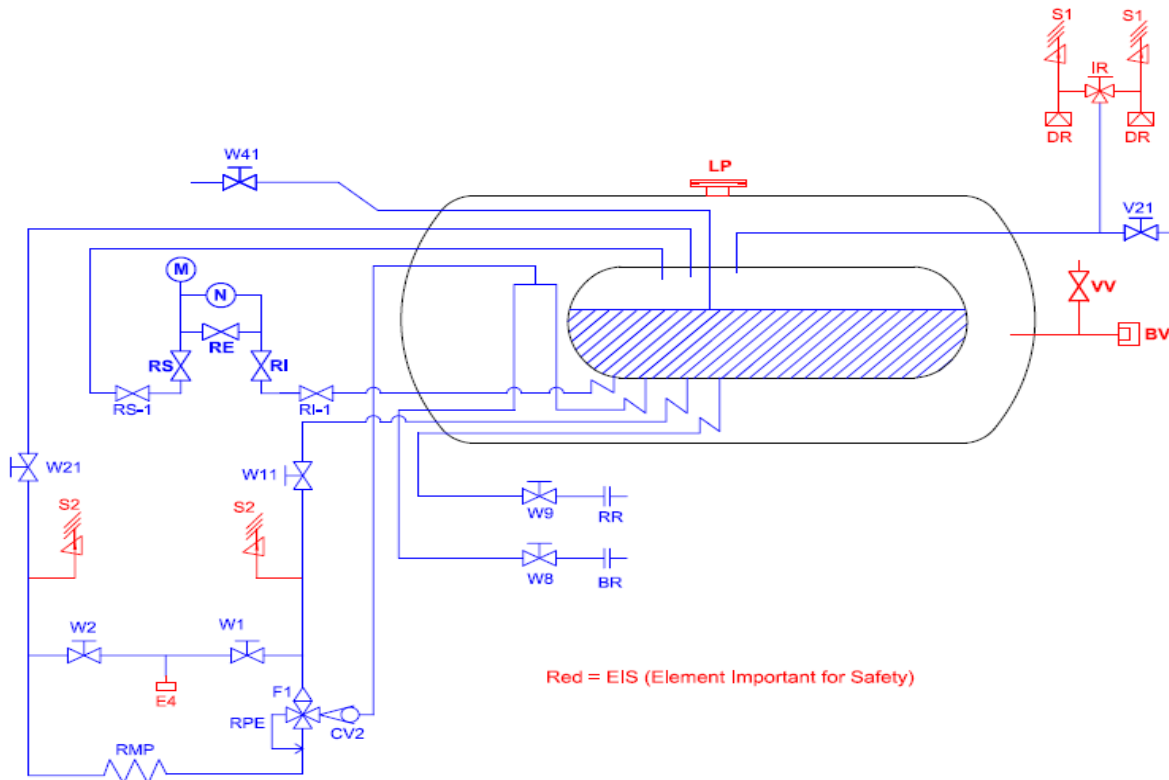

Red = EIS (Element Important for Safety)

REFERENCE	NOMENCLATURE	SIZE
W1, W11	Bottom Filling Valves	DN 25 < 21 kl Tanks
W2, W21	Top Filling Valves	DN 40 ≥ 21 kl Tanks
S3-S4	Line Safety Valve	1/4"
E4	Filling Connection	DN 40
S1	Inner Vessel Safety Valve	1/2"
DR	Inner Vessel Protection Device	1/2"
IR	3-Way Valve	DN 20
M	Pressure Indicator	-
N	Level Indicator	
RI	Level Gauge Manifold, Liquid	
RE	Level Gauge Manifold, Equalizer	
RS	Level Gauge Manifold, Gas	
W41	Full trycock Valve	DN 15
LP	Lift Plate	As per Cryolor design
BV	Vacuum Connection	-
W8 + BR	Withdrawal Valve - Gas + Connection	DN 25 < 21 kl Tanks
W9 + RR	Withdrawal Valve - Liquid + Connection	DN 40 ≥ 21 kl Tanks
RPE & F	Pressure Regulator / Economizer with Filter	-
CV1	Check Valve	
RMP	Pressure Building Coil	
V21	Vent Valve	DN 25
VV	Vacuum probe isolation valve	-

Note: All operating valves are "Bestobell" make as per standard.

HORIZONTAL CRYOGENIC STORAGE TANK

EFHA 17 BAR

FLOW DIAGRAM (with options)

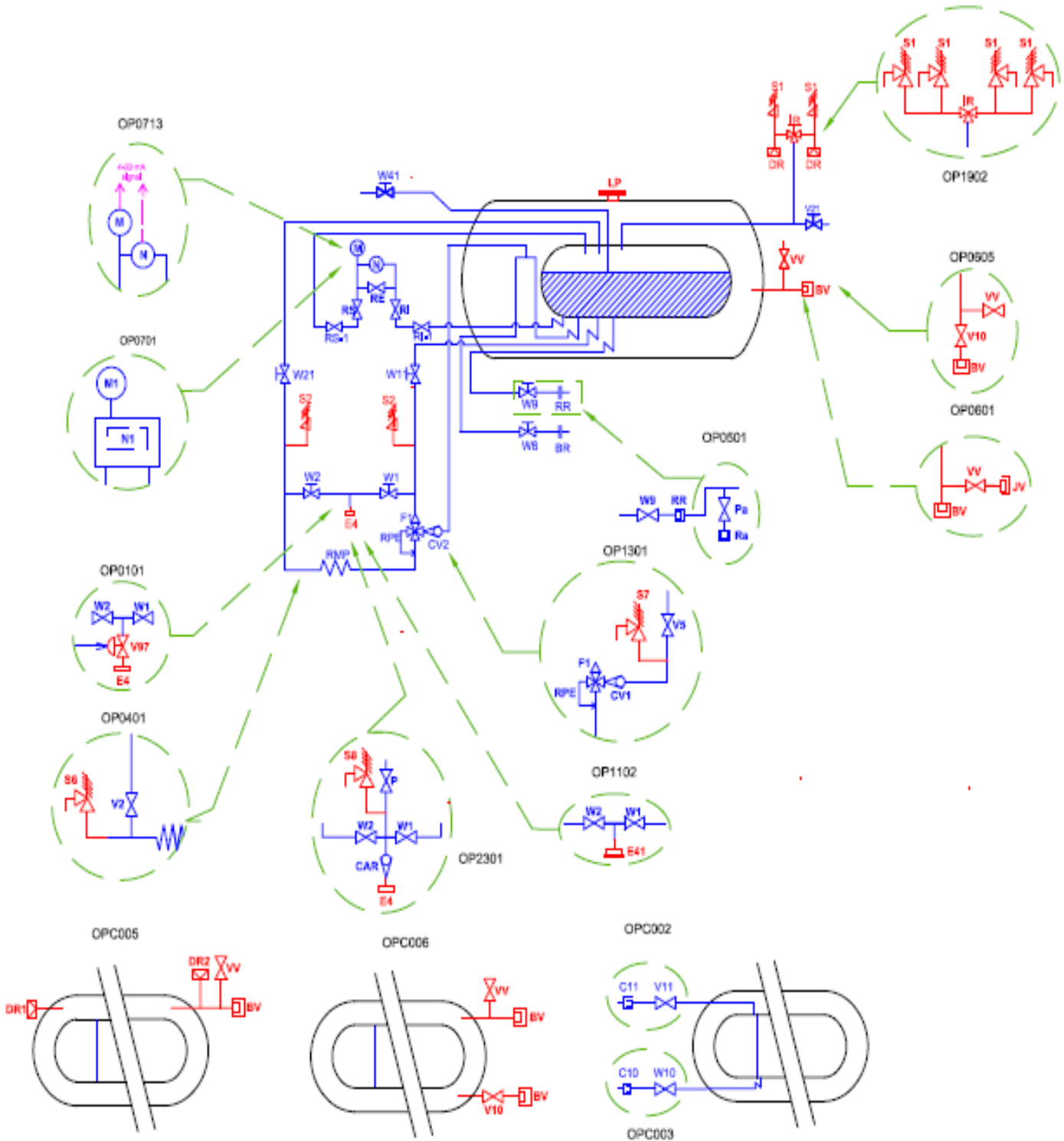

HORIZONTAL CRYOGENIC STORAGE TANK

EFHA 17 BAR

REFERENCE	NOMENCLATURE (OPTIONS)	SIZE
OP0101	Over pressurization protection (To avoid over pressure filling & Ensure vessel safety while filling)	
V97	Over pressurization protection valve	DN 40
C6	MG 97 valve connection	
OP0401	Pressure Building Coil Isolation valve	
S6	Line Safety Valve	1/4"
V2	Pressure Building Coil Isolating Valve	DN 15
OP0501	Liquid Analysis Connection	
Pa	Liquid Analysis Valve	DN 15
Ra	Quick Connection	
OP0601	Annular space vacuum detection / Vacuum sensor / Vacuum measuring probe	
VV	Vacuum Isolation Valve	1/8"
JV	Vacuum Thermocouple Connection	1/8"
OP0605	Vacuum Isolation valve	
V10	Vacuum isolation valve -Edwards Vacuum valve Type SP10K & SP25K	
OP0701	Teleflo Diva	
M1 & N1	Digital Level indicator & Analog Pressure indicator	
OP0713	Wika with Telemetry (4-20mA) option 4-20 mA Telemetry provision with wika gauge	
OP1102	ISO filling connection / Optional adaptor 1 1/2" 300 lbs	
E41	ISO Flange connection for Filling	DN 40
OP1301	Economizer Isolation valve	
V5	Globe Valve With Check	DN 15
S7	Line Safety Valve	1/4"
OP1902	Additional safety relief valves 4 Number of safety relief valves without bursting disc	
OP2301	Filling assembly with Check valve, Check valve & Purge valve	
S8	Line Safety Valve	1/4"
P	Purge Valve	
CAR	Check Valve	
OP5301	Footprint template Footprint drawing available before tank shipment (For foundation work at customer site)	
OPC001	10% Trycock Net capacity of tank with 10% gas phase	
OPC002	Additional Top filling / Gas withdrawal line	
V11	Top filling / Gas withdrawal valve	DN 25 < 21 kl Tanks
C11	Top filling / Gas withdrawal connection	DN 40 ≥ 21 kl Tanks
OPC003	Additional Liquid withdrawal line	
W10	Liquid withdrawal valve	DN 25 < 21 kl Tanks
C10	Liquid withdrawal connection	DN 40 ≥ 21 kl Tanks
OPC005	Rupture disc for Outer vessel safety relief	
DR1 & DR2	Vacuum bursting disc (Instead of lift plate)	
OPC006	Additional vacuum pumping line for vacuum valve	
BV	Vacuum pump down connection	
V10	Vacuum isolation valve -Edwards Vacuum valve Type SP10K & SP25K	

HORIZONTAL CRYOGENIC STORAGE TANK

EFHA 17 BAR

REFERENCE	NOMENCLATURE (OPTIONS)	SIZE
OPC007	ANSI flange connection on withdrawals	
	ANSI flange connection on withdrawals (Instead of 3 part coupling)	
OPC008	Metal P&ID	
	Metal P&ID instead of Laminated sheet P&ID	
OPC009	Upsizing liquid withdrawal valve (W9) to DN 50 / 2"	
	Liquid withdrawal valve size increased to DN50 / 2" (Valve size DN50, Pipe size DN25/DN40)	
OPC010	Liquid withdrawal line (W9) to DN 50 / 2"	
	Liquid withdrawal line size DN50 / 2" (Both Pipe & Valve)	
OPC012	LAR-CGA connection on Filling cluster	
	CGA-Filling connection for Liquid Argon	
OPC013	LOX-CGA connection on Filling cluster	
	CGA-Filling connection for Liquid Oxygen	
OPC014	LIN-CGA connection on Filling cluster	
	CGA-Filling connection for Liquid Nitrogen	
OPC015	MOM Certificate	
	MOM certificate available	
OPC016	Herose valves (Instead of Bestobell valves)	
	Operating valves are Herose make, instead of Bestobell make	
OPC017	Customer LOGO	
	Customer requirement LOGO fixed on tank.	

Note (*):

- This technical specification is purely an indication, It can't be considered as a contractual document.
- This technical specification is subject to change without prior intimation.